

FIN XS / FIN XS POLE

IP65 \ IK05

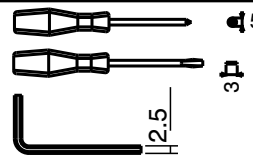

FIN XS A

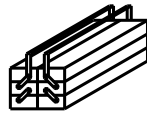
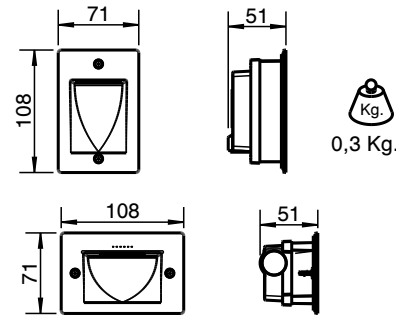

FIN XS POLE B

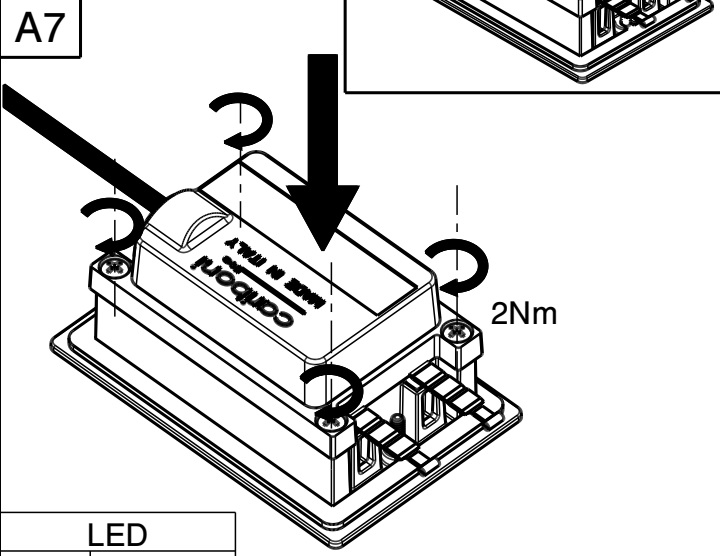
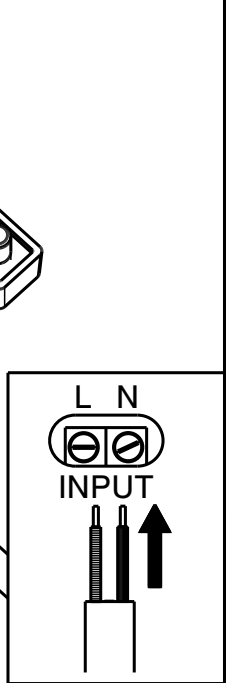
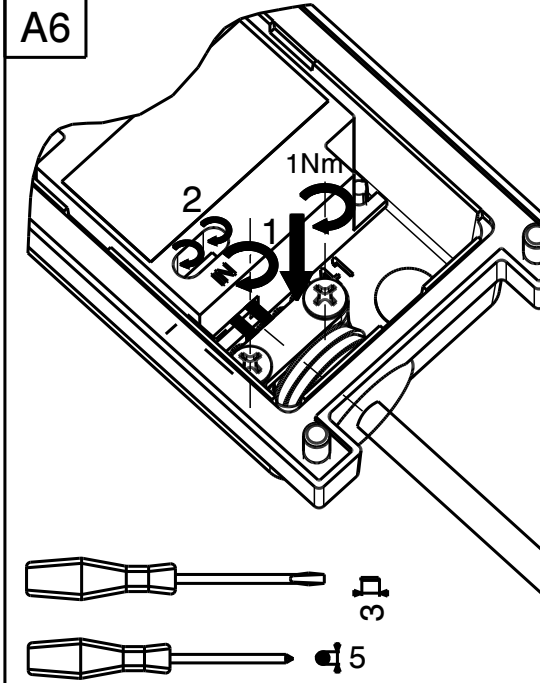
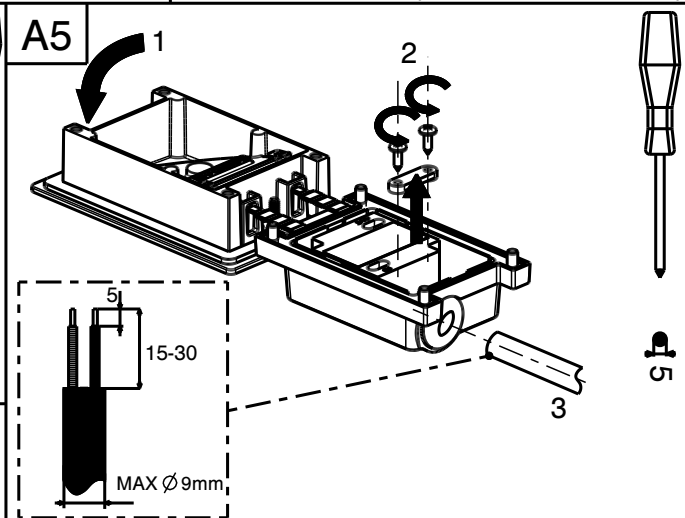
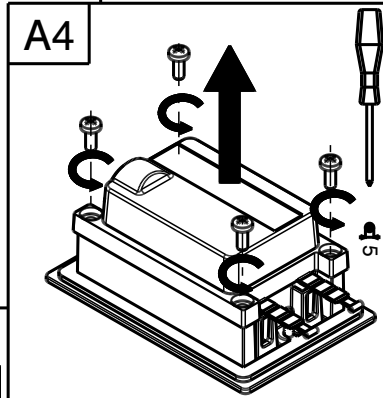
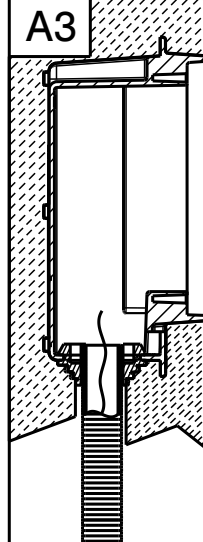
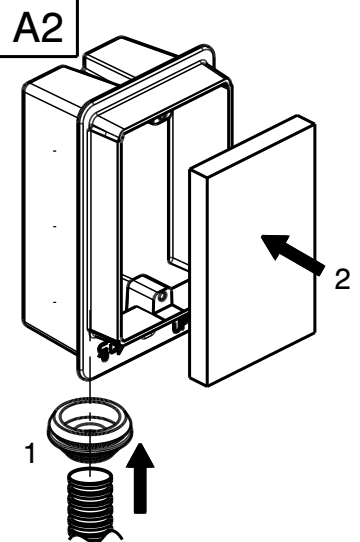
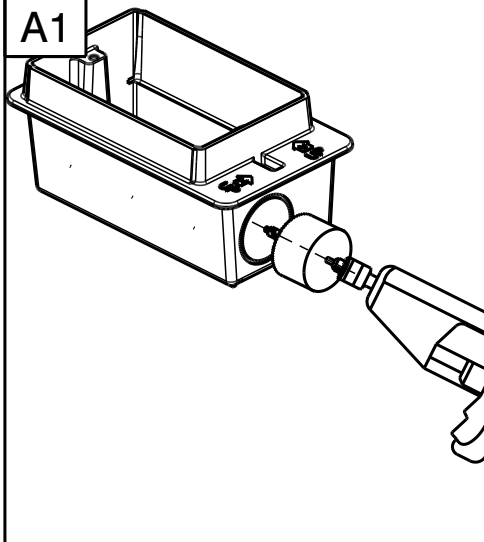
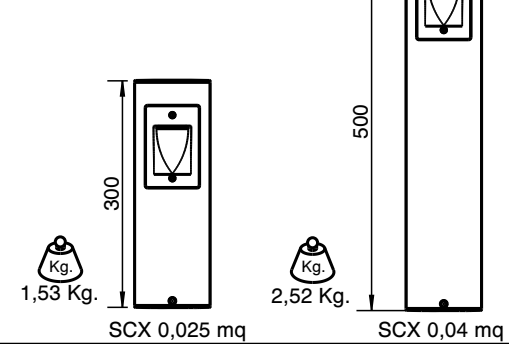

LED	
Potenza Power Puissance Leistung Potencia	4W
Colore Colour Couleur Farbe Color	3000K WARM WHITE 4000K NEUTRAL WHITE
Tensione Voltage Tension Spannung Tensión	220V-240V 50Hz-60Hz

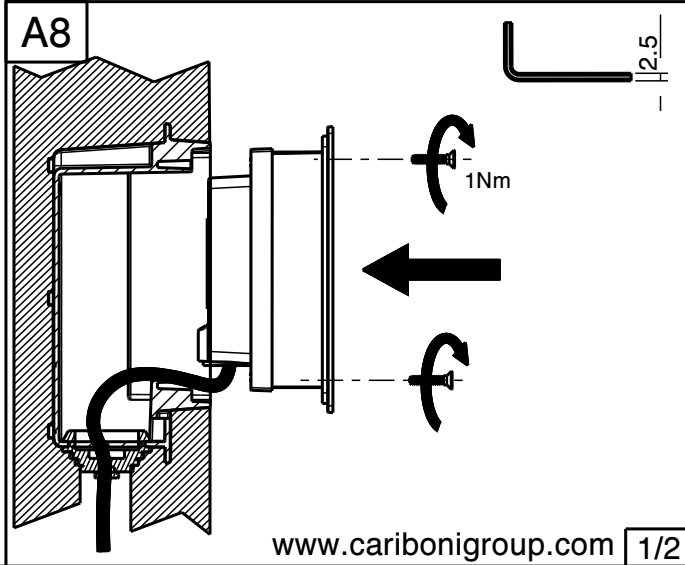

COD. 207083380 (14/05/2012)

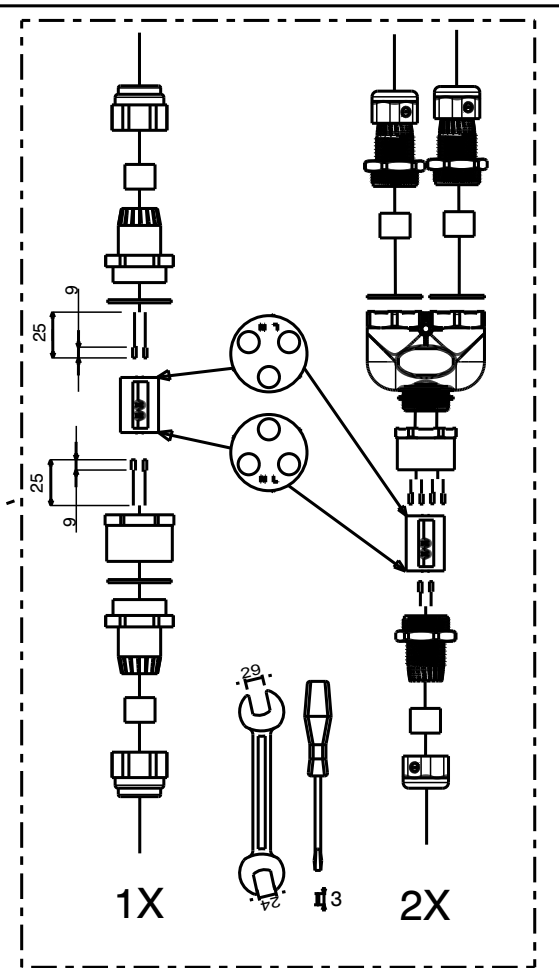
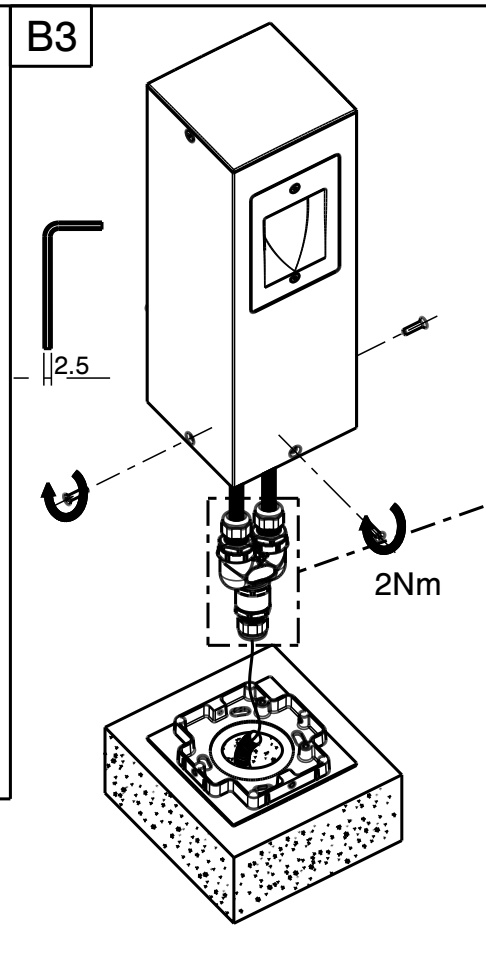
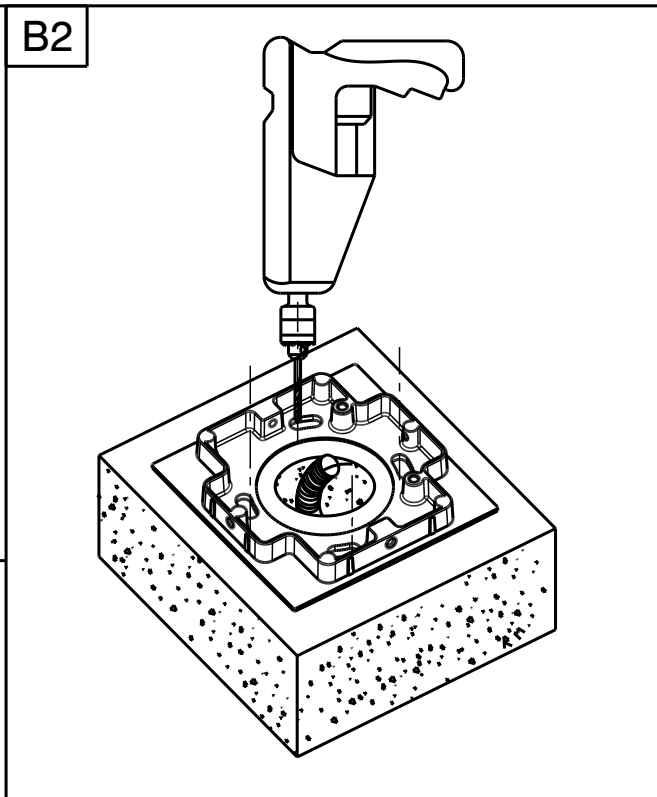
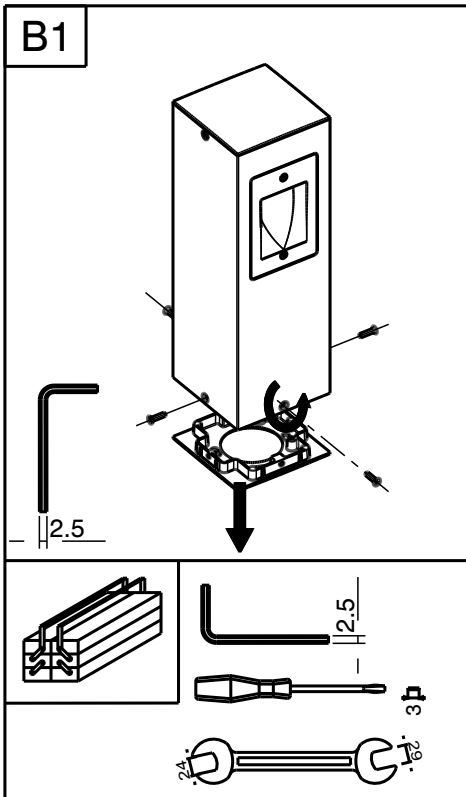

IT

EN

FR

DE

ES

Seguire attentamente le istruzioni per garantire un funzionamento corretto e sicuro
 Conservare l'etichetta dell'imballo per consentire la rintracciabilità del lotto di produzione ,in caso di reclamo
 Il prodotto non deve essere modificato. Qualsiasi modifica annulla la garanzia e può rendere pericoloso il prodotto
 Togliere tensione in caso di manutenzione.
 La Cariboni lite S.r.l. declina ogni responsabilità per i danni causati da un proprio prodotto montato in modo non conforme alle istruzioni.
 Led bianco: apparecchio con RADIAZIONE LED di Classe2 secondo CEI EN 60825-1:2003,ed IV. Non fissare il fascio.
 L'apparecchio non deve, in alcuna circostanza, essere coperto con materiale isolante o similare.

Please carefully observe the instructions to achieve a correct and safe functioning.
 Please keep the packing label to enable the product lot identification in case of claim
 Never modify the product. Any modification will cancel the guarantee and it can make the product dangerous
 Please disconnect from supply net while replacing lamp or doing any maintenance.
 Cariboni lite S.r.l. declines any responsibility for damages, which can be caused by its own products if they are not assembled and installed in conformity with instructions.
 White Led: Floodlight with LED RADIATION Classe2 in conformity with CEI EN 60825-1 2003,ed. IV. Do not stare at the light source.
 The fitting shan t in any case be covered with any insulating material or similar.

Observer soigneusement les instructions afin d assurer un fonctionnement correct et en sécurité
 Garder l étiquette de l emballage pour permettre l identification du lot de production en cas de litige
 Ne jamais modifier le produit. Quelconque changement annule la garantie et peut rendre le produit dangereux
 Déconnecter du réseau en cas de remplacement de la lampe ou entretien.
 Cariboni lite S.r.l. décline toute responsabilité pour les dommages causés par ses produits si assemblés et installés de façon non-conforme aux instructions.
 Led Blanc: Appareil avec RADIATION LED Classe2 selon la norme CEI EN 60825-1 2003,ed.IV. Ne pad fixer le faisceau.
 L appareil ne doit pas être couvert avec des matériaux isolants ou similaires.

Bitte Hinweisen beachten, um einen korrekten und sicheren Betrieb zu gewährleisten.
 Aufheben Sie die Verpackungsetikette, um die Produktionspartie im Fall von Reklamation zu identifizieren.
 Das Gerät muss unbedingt nicht verändert werden; jede Änderung wird die Garantie des Produkts annullieren und kann das Gerät gefährlich machen.
 Bei der Ersetzung des Leuchtmittels, abnehmen Sie die Spannung.
 Cariboni Lite Srl erkennt keine Verantwortung für Schaden, die von solchen Produkten verursacht werden, die nicht gemäß diesen Montageanleitungen installiert wurden.
 Bei WEIßEN LED: Gerät mit LED Lichtausstrahlung der Klasse 2, gemäß der Norm CEI EN 60825-1:2003, ed IV.
 Nie auf den Lichtbündel starren.
 Das Gerät darf auf keinem Fall mit Isolierstoffen oder ähnliche Stoffen verdeckt werden.

Seguir atentamente las instrucciones para garantizar un funcionamiento correcto y seguro
 Conservar la etiqueta del embalaje para tener la información del lote de producción para cualquier reclamación.
 El producto no debe ser modificado. Cualquier cambio anula la garantía y puede hacer peligroso el producto.
 Cortar la alimentación para el cambio de la lámpara o para cualquier mantenimiento
 Cariboni Lite, S.R.L. no acepta ninguna responsabilidad por daños causados por un producto montado de forma no conforme a las instrucciones.
 Led Blanco: Aparato con RADIACION DE LED de Clase2 segundo CEI 60825-1 2003,ed.IV. No mirar directamente al haz de luz.
 El aparato no debe cubrirse, bajo ninguna circunstancia, con ningún material aislante o similar.

VIA DELLA TECNICA 19
 I-23875 OSNAGO (LC)
 TEL. 039/587506
 FAX 039/9520006

VIA PRATO 22
 I-38068 ROVERETO (TN)
 TEL. 0464/422247
 FAX 0464/430393

VIA DELLA TECNICA 19
 I-23875 OSNAGO (LC)
 TEL. 039/9521.1
 FAX 039/587812

FIN / FIN POLE

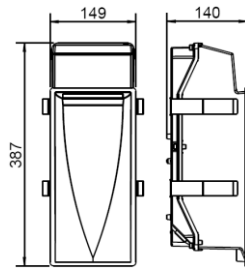
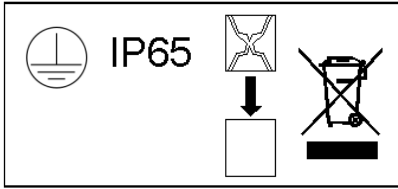

FIN A

4,7Kg

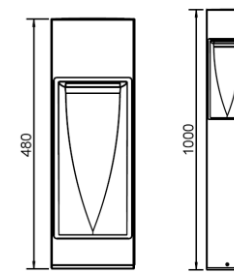

FIN-POLE B

480

1000

5,5 Kg

10 Kg

SCX 0,076 m²

SCX 0,156 m²

A1

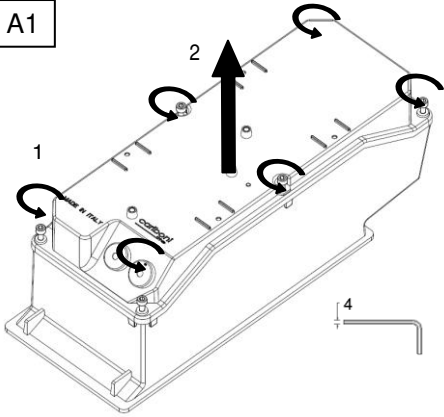

A2

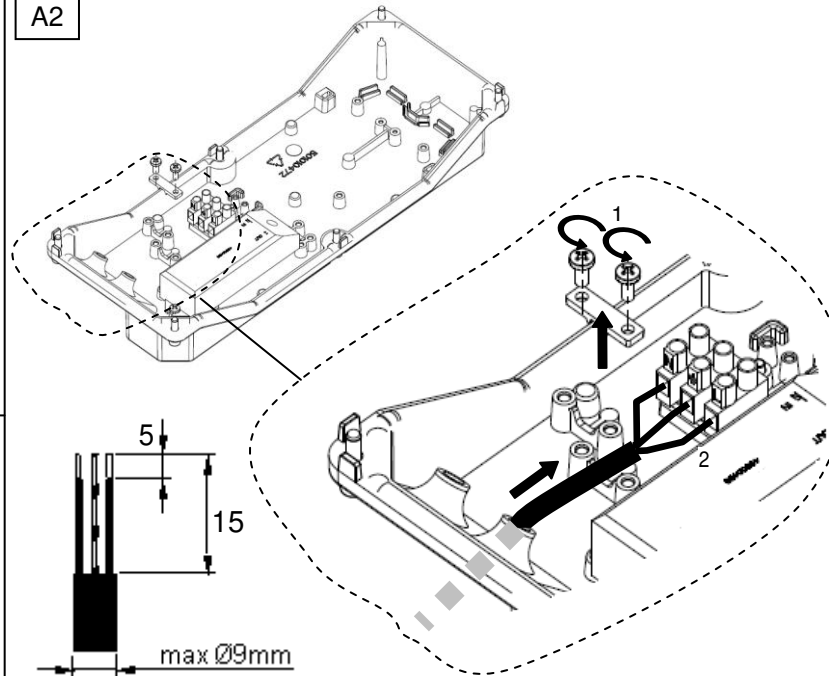

A5

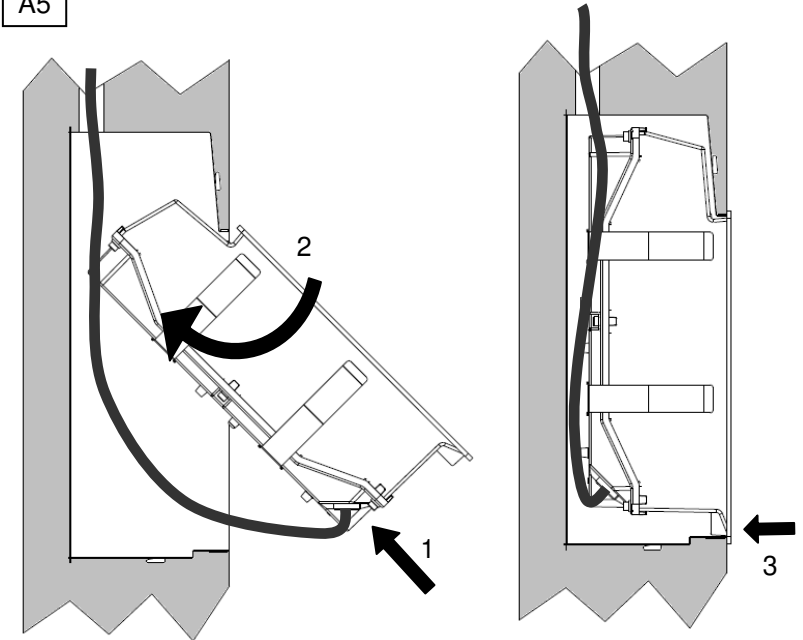

A3

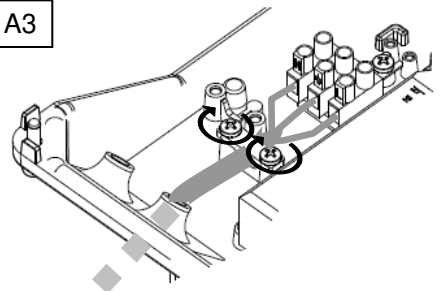

A4

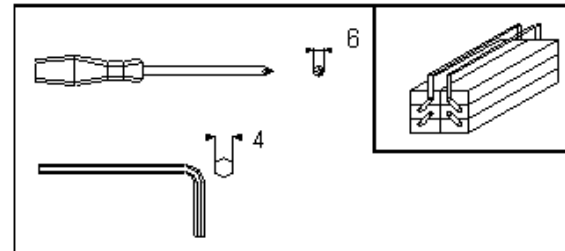
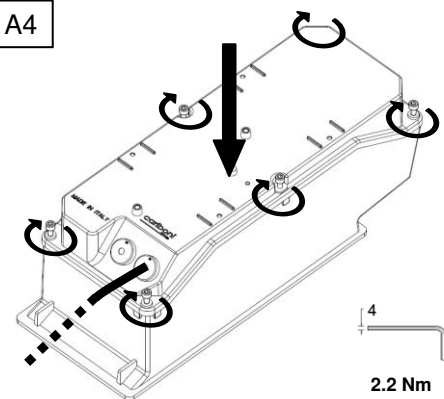

LAMP

Potenza Power Puissance Leistung Potencia	20W MT GU 6.5
Tensione Voltage Tension Spannung Tensión	230 V
Frequenza Frequency Frèquence Frequenz Frecuencia	50 ÷ 60 Hz

LED

Potenza Power Puissance Leistung Potencia	10,5W (9 LED)
Colore Colour Couleur Farbe Color	3000 °K (WARM WHITE)
	4000 °K (NEUTRAL WHITE)
Tensione Voltage Tension Spannung Tensión	230 V

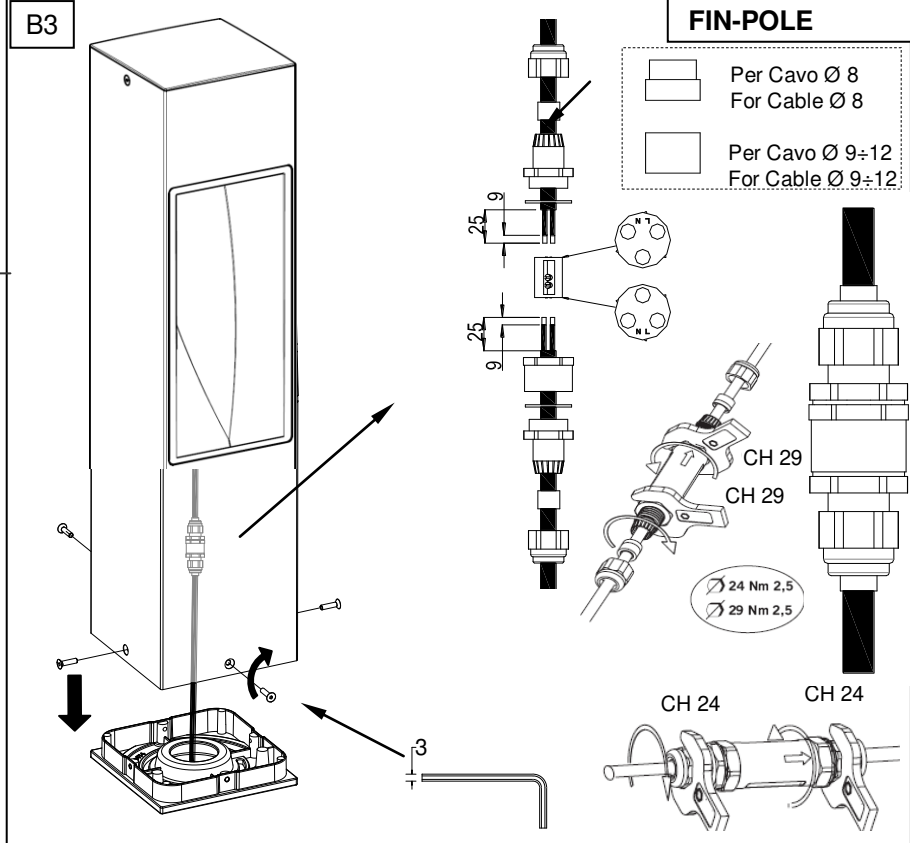
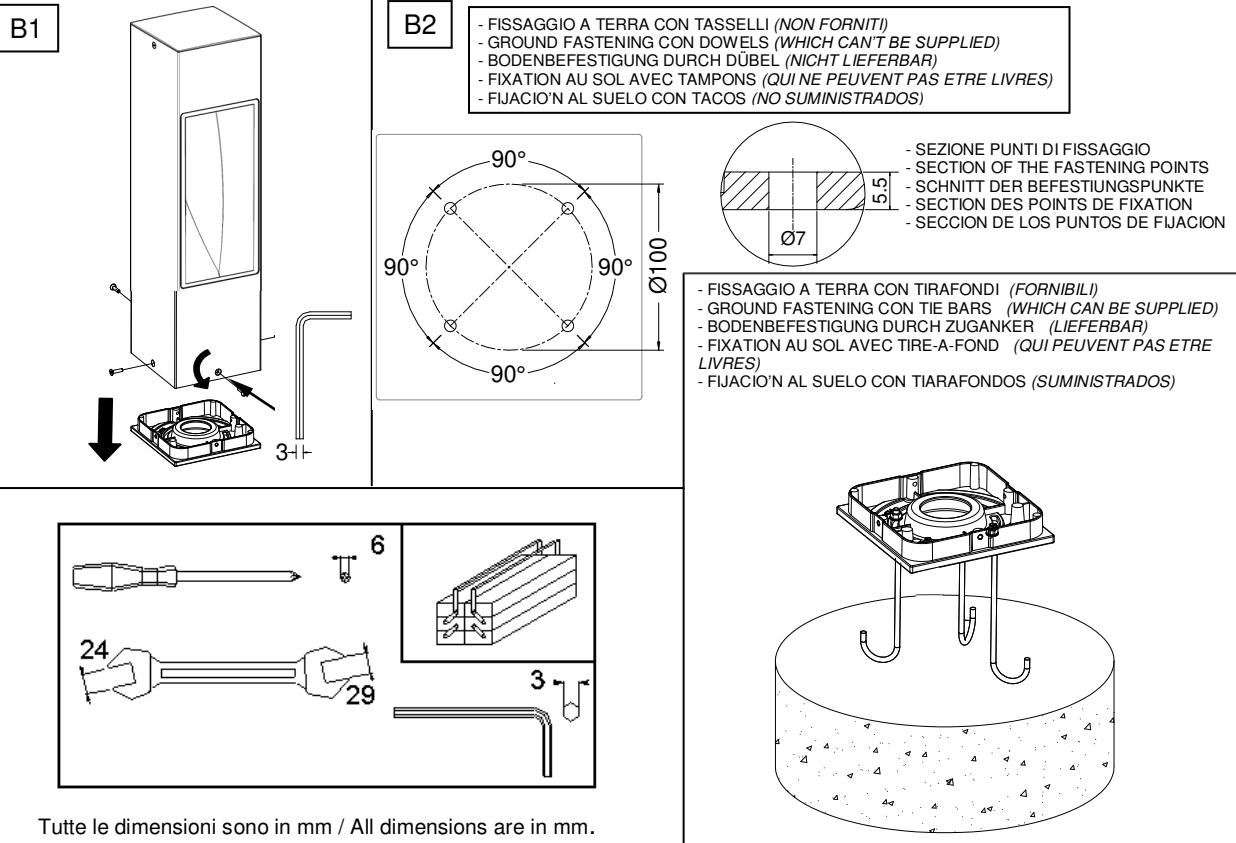

Tutte le dimensioni sono in mm / All dimensions are in mm.

I	ENG	F	D	ESP
<p>Seguire attentamente le istruzioni per garantire un funzionamento corretto e sicuro Conservare l'etichetta dell'imballo per consentire la rintracciabilità del lotto di produzione ,in caso di reclamo Il prodotto non deve essere modificato. Qualsiasi modifica annulla la garanzia e può rendere pericoloso il prodotto Togliere tensione in caso di manutenzione. La Cariboni lite S.r.l. declina ogni responsabilità per i danni causati da un proprio prodotto montato in modo non conforme alle istruzioni. Led bianco: apparecchio con RADIAZIONE LED di Classe2 secondo CEI EN 60825-1:2003,ed IV. Non fissare il fascio. L'apparecchio non deve, in alcuna circostanza, essere coperto con materiale isolante o similare.</p>	<p>Please carefully observe the instructions to achieve a correct and safe functioning. Please keep the packing label to enable the product lot identification in case of claim Never modify the product. Any modification will cancel the guarantee and it can make the product dangerous Please disconnect from supply net while replacing lamp or doing any maintenance. Cariboni lite S.r.l. declines any responsibility for damages, which can be caused by its own products if they are not assembled and installed in conformity with instructions. White Led: Floodlight with LED RADIATION Class2 in conformity with CEI EN 60825-1 2003,ed. IV. Do not stare at the light source. The fitting shan't in any case be covered with any insulating material or similar.</p>	<p>Observer soigneusement les instructions afin d'assurer un fonctionnement correct et en sécurité Garder l'étiquette de l'emballage pour permettre l'identification du lot de production en cas de litige Ne jamais modifier le produit. Quelconque changement annule la garantie et peut rendre le produit dangereux Déconnecter du réseau en cas de remplacement de la lampe ou entretien. Cariboni lite S.r.l. décline toute responsabilité pour les dommages causés par ses produits si assemblés et installés de façon non-conforme aux instructions. Led Blanc: Appareil avec RADIATION LED Classe2 selon la norme CEI EN 60825-1 2003,ed.IV. Ne pad fixer le faisceau. L'appareil ne doit pas être couvert avec des matériaux isolants ou similaires.</p>	<p>Bitte Hinweisungen beachten, um einen korrekten und sicheren Betrieb zu gewährleisten. Aufheben Sie die Verpackungsetikette, um die Produktionspartie im Fall von Reklamation zu identifizieren. Das Gerät muss unbedingt nicht verändert werden; jede Änderung wird die Garantie des Produkts annullieren und kann das Gerät gefährlich machen. Bei der Ersetzung des Leuchtmittels, abnehmen Sie die Spannung. Cariboni Lite Srl erkennt keine Verantwortung für Schaden, die von solchen Produkten verursacht werden, die nicht gemäß diesen Montageanleitungen installiert wurden. Bei WEIßEN LED: Gerät mit LED Lichtausstrahlung der Klasse 2, gemäß der Norm CEI EN 60825-1:2003, ed IV. Nie auf den Lichtbündel starren. Das Gerät darf auf keinem Fall mit Isolierstoffen oder ähnliche Stoffen verdeckt werden.</p>	<p>Seguir atentamente las instrucciones para garantizar un funcionamiento correcto y seguro Conservar la etiqueta del embalaje para tener la información del lote de producción para cualquier reclamación. El producto no debe ser modificado. Cualquier cambio anula la garantía y puede hacer peligroso el producto. Cortar la alimentación para el cambio de la lámpara o para cualquier mantenimiento Cariboni Lite, S.R.L. no acepta ninguna responsabilidad por daños causados por un producto montado de forma no conforme a las instrucciones. Led Blanco: Aparato con RADIACION DE LED de Clase2 segundo CEI 60825-1 2003,ed.IV. No mirar directamente al haz de luz. El aparato no debe cubrirse, bajo ninguna circunstancia, con ningún material aislante o similar.</p>

